

## SMD Type※Top view Package CL-SP1010RGB-02

### Features

- 1010 package
- Top view LED
- Package in 8mm tape on 14" diameter reel
- Compatible with infrared and vapor phase reflow solder process.
- Pb-free
- RoHS compliant

### Description

- The CIEL 1010 SMD LED is much smaller than lead frame type components,thus enable smaller board size, higher packing density,reduced storage space and finally smaller equipment to be obtained.
- Besides,lightweight makes them ideal for miniature applications etc.

### Applications

- General lighting
- Decorative and Entertainment Lighting
- Signal and Symbol Luminary
- Automotive Telecommunication
- backlighting in dashboard and switch

### Device Selection Guide

Chip Material		Emitted Color	Resin Color
R6	AlGaInP	Brilliant Red	Water Clear
GH	AlGaInP	BrilliantGreen	
B1	AlGaInP	BrilliantBlue	

## Absolute Maximum Ratings (Ta=25°C)

Parameter	Symbol	Rating	Unit
Forward Current	I <sub>F</sub>	25	mA
Peak Forward Current (Duty 1/10 @1ms)	I <sub>FP</sub>	100	mA
Power Dissipation	P <sub>d</sub>	R6:55	mW
		GH:80	mW
		B1:80	mW
Operating Temperature	T <sub>opr</sub>	-30 ~ +85	°C
Storage Temperature	T <sub>stg</sub>	-40 ~ +90	°C
Soldering Temperature	T <sub>sol</sub>	Reflow Soldering : 260 °C for 10 sec. Hand Soldering : 350 °C for 3 sec.	
Reverse Voltage	V <sub>R</sub>	10	V

### Note:

The products are sensitive to static electricity and must be carefully taken when handling products.

## Electro-Optical Characteristics (Ta=25°C)

Parameter	Symbol	Min.	Typ.	Max.	Unit	Condition	
Reverse Current	IR	---	---	1	μA	VR=10V	
Viewing Angle	2θ1/2	---	115	---	deg	IF=5mA	
Forward Voltage	VF	R6	1.7	---	2.3	V	IF=5mA
		GH	2.5	---	3.5		
		B1	2.5	---	3.5		
Luminous Intensity	I <sub>v</sub>	R6	---	45	---	mcd	IF=5mA
		GH	---	230	---		
		B1	---	55	---		
Doninant Wavelength	λ <sub>d</sub>	R6	618.5	---	625.5	nm	IF=5mA
		GH	520	---	530		
		B1	463	---	472		

### Notes:

- 1.Tolerance of Luminous Intensity ±10%.
- 2.Tolerance of Forward Voltage : ±0.1V.
- 3.Tolerance of Dominant Wavelength: ±1nm

## Package Dimensions

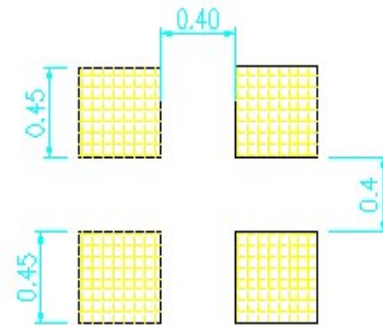
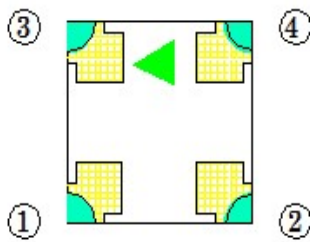
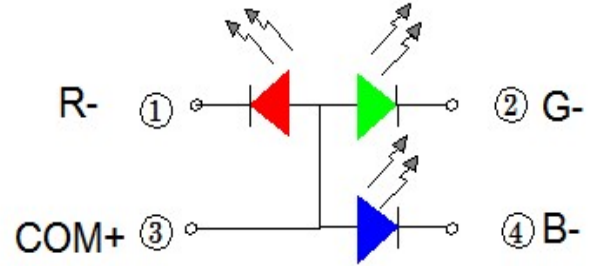
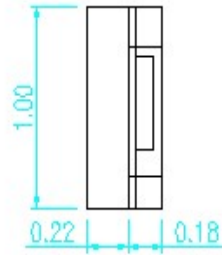
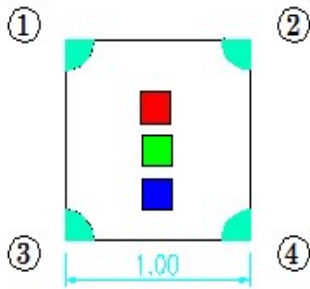
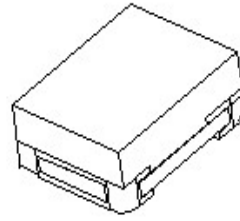
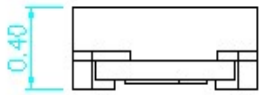

建议焊盘尺寸

**Note:** Tolerance unless mentioned is  $\pm 0.1$  mm, Unit = mm.

# Typical Electro-Optical Characteristics Curves

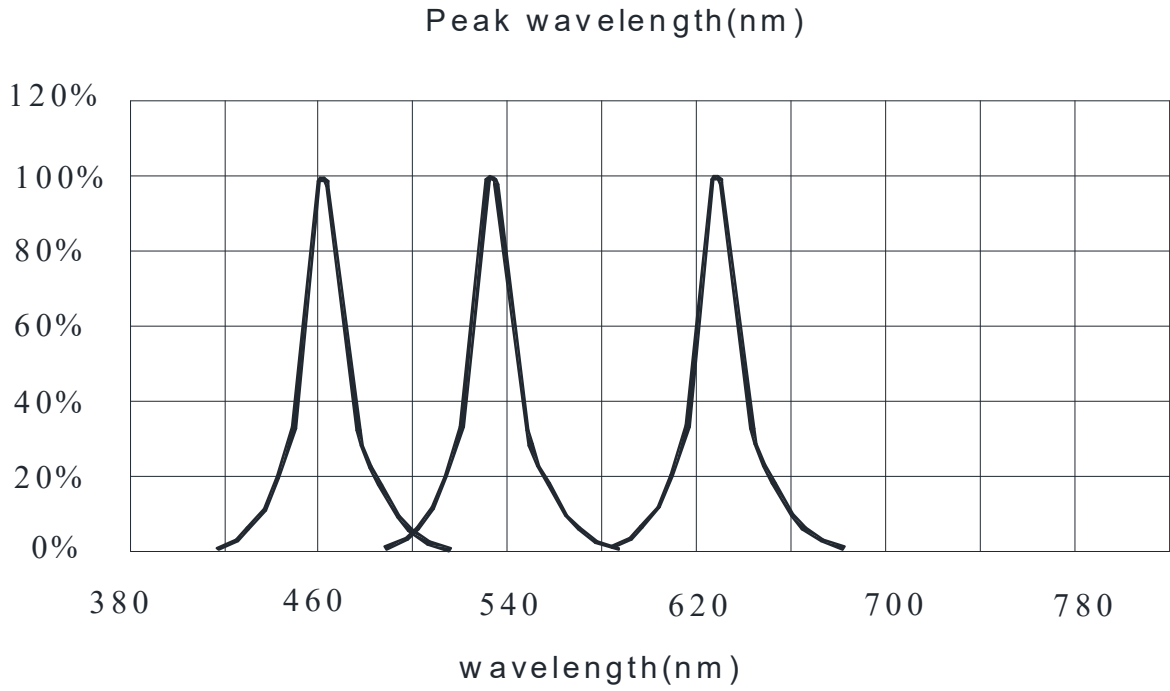

Fig.1-Forward Current(V) vs. Forward Voltage

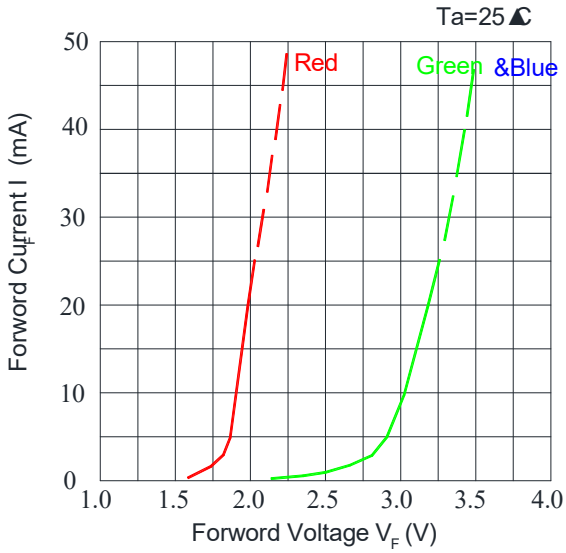
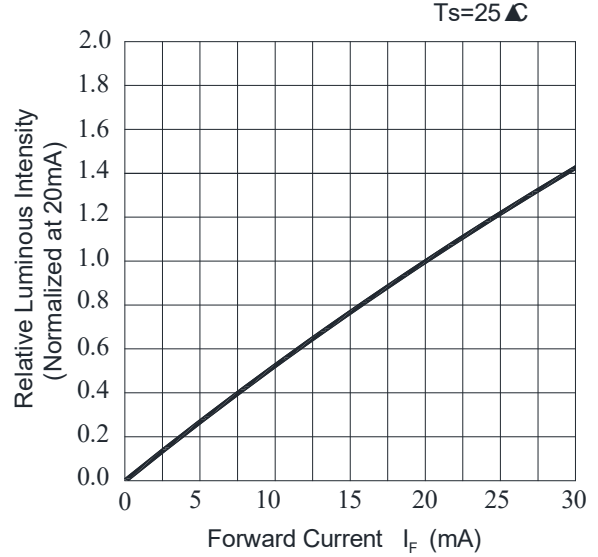

Fig.2-Relative Luminous Intensity vs. Forward Current



# Typical Electro-Optical Characteristics Curves

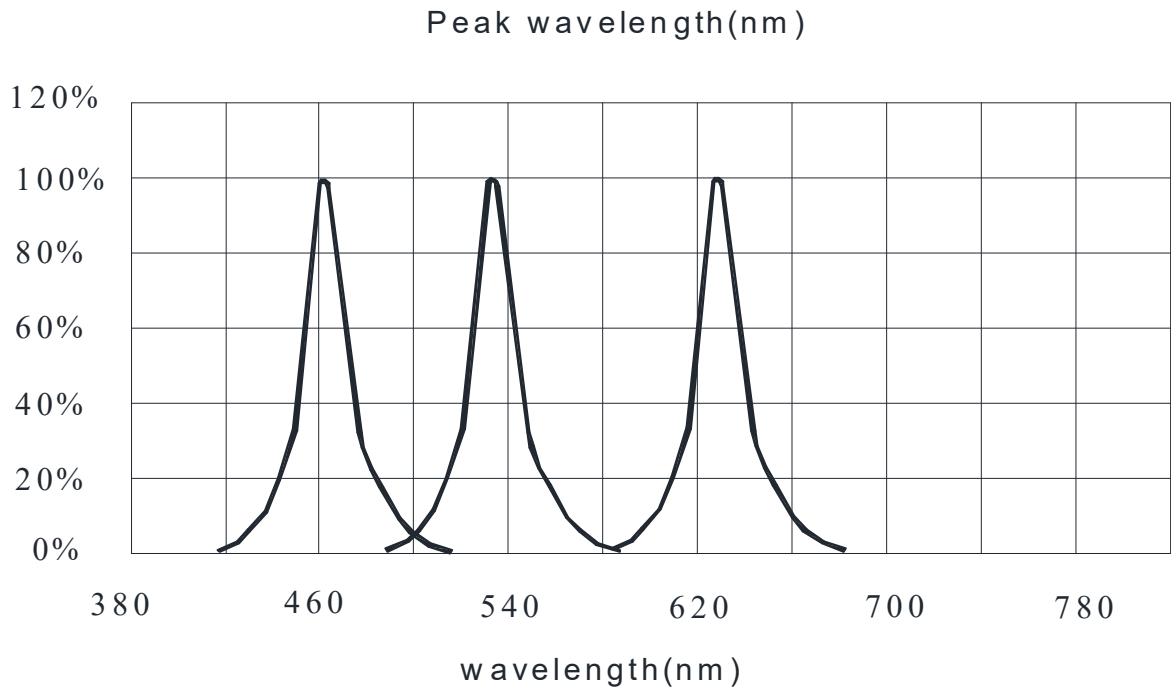

Fig.1-Forward Current(V) vs. Forward Voltage

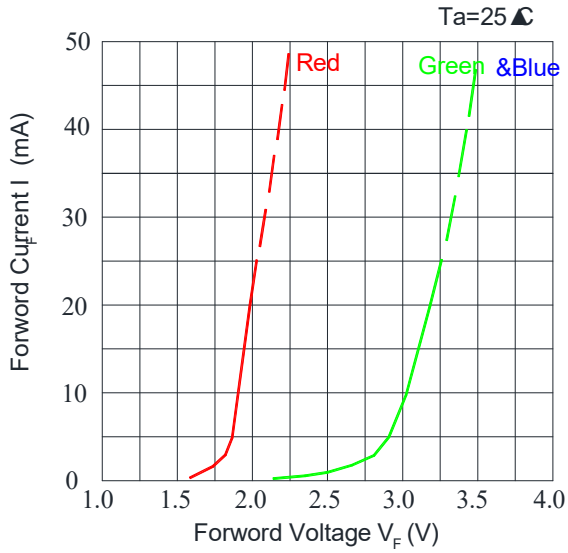
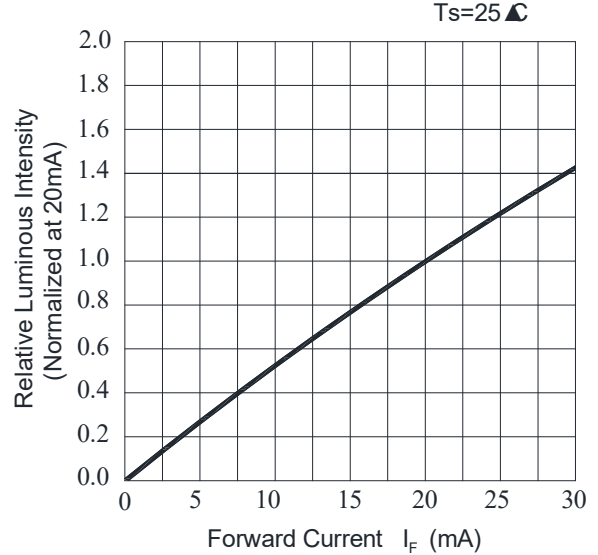

Fig.2-Relative Luminous Intensity vs. Forward Current



## Label Form Specification

CPN: Customer's Production Number

P/N : Production Number

QTY: Packing Quantity

CAT: Ranks

HUE: Peak Wavelength

REF: Reference

LOT No: Lot Number

## Reel Dimensions

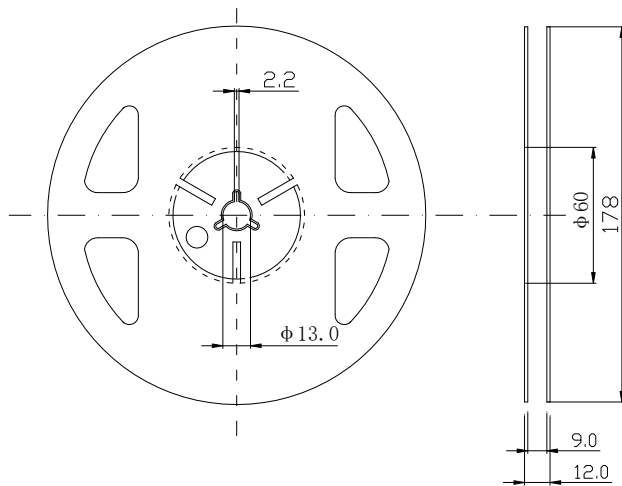

**Note:** The tolerances unless mentioned is  $\pm 0.1\text{mm}$ , Unit = mm

**Carrier Tape Dimensions:(Quantity: 4000pcs/Reel)**

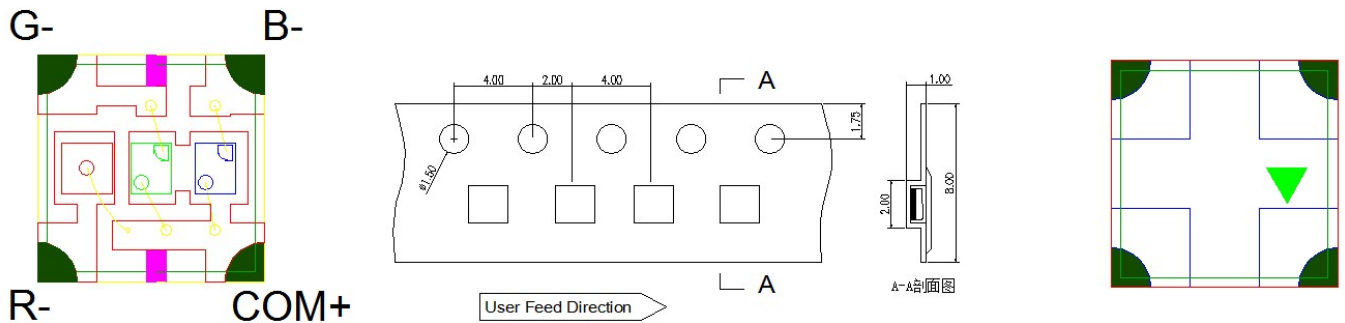

### Note:

1. Tolerance unless mentioned is  $\pm 0.1\text{mm}$ , Unit = mm.
2. Minimum packing amount is 1000/2000 pcs per reel.

## Moisture Resistant Packing Process

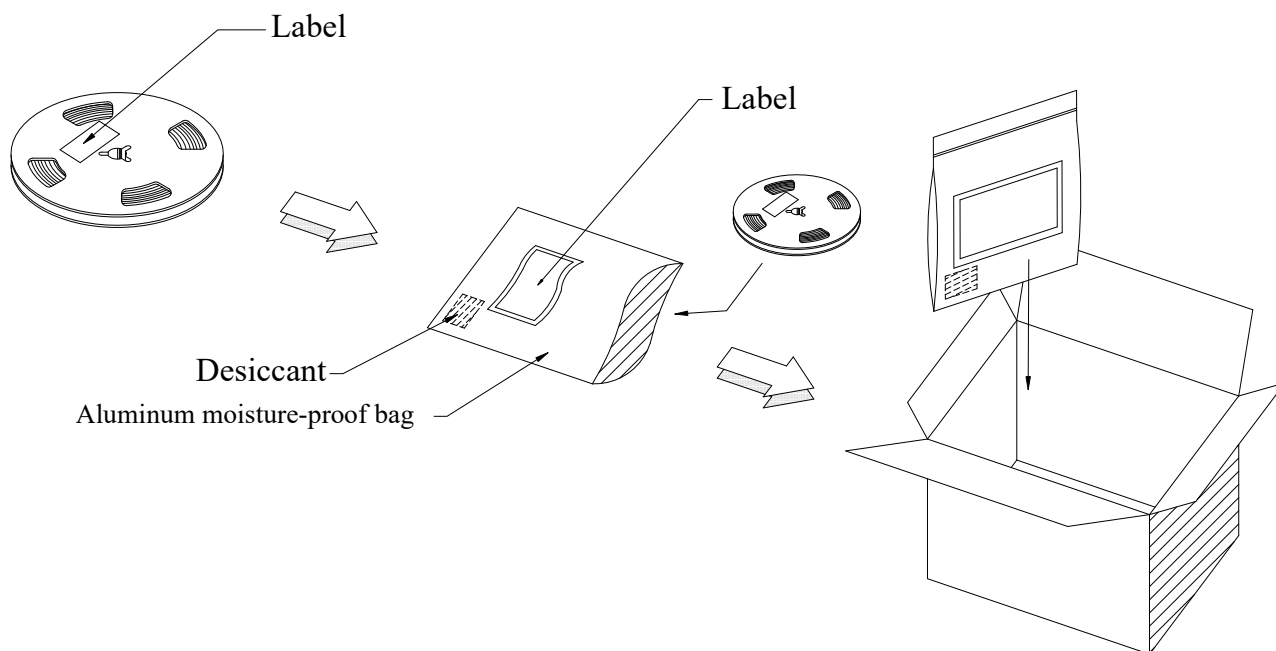

## Reliability Test Items and Conditions

The reliability of products shall be satisfied with items listed below.

Confidence level : 90%

LTPD : 10%

No.	Items	Test Condition	Test Hours/Cycles	Sample Size	Ac/Re
1	Reflow Soldering	Temp. : 260°C/10sec.	6 Min	22 PCS	0/1
2	Thermal Shock	H : +100°C 5min   10 sec L : -10°C 5min	300 Cycles	22 PCS	0/1
3	Temperature Cycle	H : +100°C 15min   5 min L : -40°C 15min	300 Cycles	22 PCS	0/1
4	High Temperature/Humidity Reverse Bias	Ta=85°C,85%RH	1000 Hrs.	22 PCS	0/1
5	Low Temperature Storage	Ta=-40°C	1000 Hrs.	22 PCS	0/1
6	High Temperature Storage	Ta=100°C	1000 Hrs.	22 PCS	0/1
7	DC Operation Life	Ta=25°C IF = 20 mA	1000 Hrs.	22 PCS	0/1

## Precautions For Use

### 1. Over-current-proof

Customer must apply resistors for protection , otherwise slight voltage shift will cause big current change ( Burn out will happen ).

### 2. Storage

2.1 Do not open moisture proof bag before the products are ready to use.

2.2 Before opening the package, the LEDs should be kept at 40°C or less and 90%RH or less.

2.3 After opening the package: The LED's floor life is 1 year under 30°C or less and 60% RH or less.

If unused LEDs remain, it should be stored in moisture proof packages

2.4 After opening the package, the LEDs should be kept at 30°C or less and 60%RH or less.

2.5 The LEDs should be used within 168 hours (7 days) after opening the package

2.6 If the moisture absorbent material (silica gel) has faded away or the LEDs have exceeded the storage time, baking treatment should be performed using the following J-STD-33 Standard.

### 3. Soldering Condition

#### 3.1 Pb-free solder temperature profile

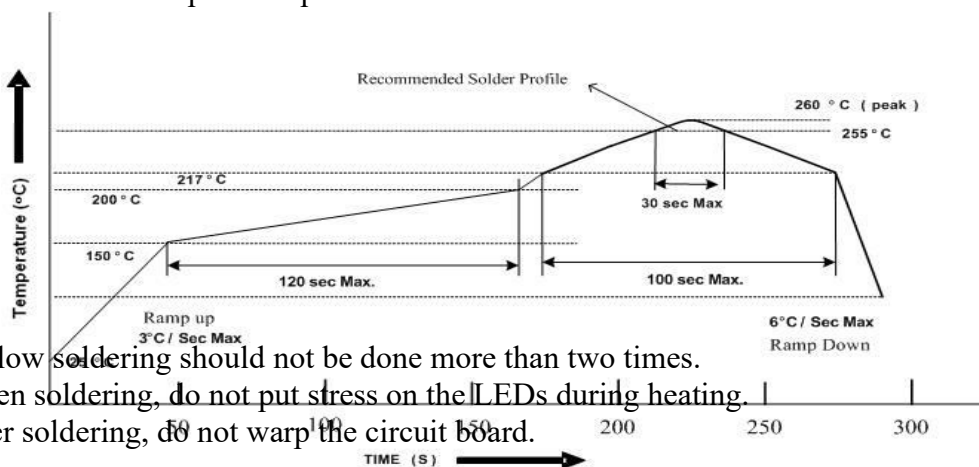

3.2 Reflow soldering should not be done more than two times.

3.3 When soldering, do not put stress on the LEDs during heating.

3.4 After soldering, do not warp the circuit board.

### 4. Soldering Iron

Each terminal is to go to the tip of soldering iron temperature less than 350°C for 3 seconds within once in less than the soldering iron capacity 25W. Leave two seconds and more intervals, and do soldering of each terminal. Be careful because the damage of the product is often started at the time of the hand solder.

### 5. Repairing

Repair should not be done after the LEDs have been soldered. When repairing is unavoidable, a double-head soldering iron should be used (as below figure). It should be confirmed beforehand whether the characteristics of the LEDs will or will not be damaged by repairing.